

- FITS STANDARD 2' X 2' T-BAR CEILING SYSTEMS
- CORROSION RESISTANT CONSTRUCTION, HEAVY GAGE (.040) ALUMINUM CONES AND BACK PANEL WITH GALVANIZED STEEL BRACKETS AND COLLAR.
- AVAILABLE IN 6-14 INCH COLLAR SIZES FACTORY MOUNTED
- REMOVABLE CENTER CORE
- OPTIONAL NO. 3800 STEEL BUTTERFLY DAMPER, ADJUSTABLE THROUGH THE FACE
- 360° PATTERN FOR HIGH AIR VOLUME DELIVERY
- FINISH: WHITE (W) ENAMEL

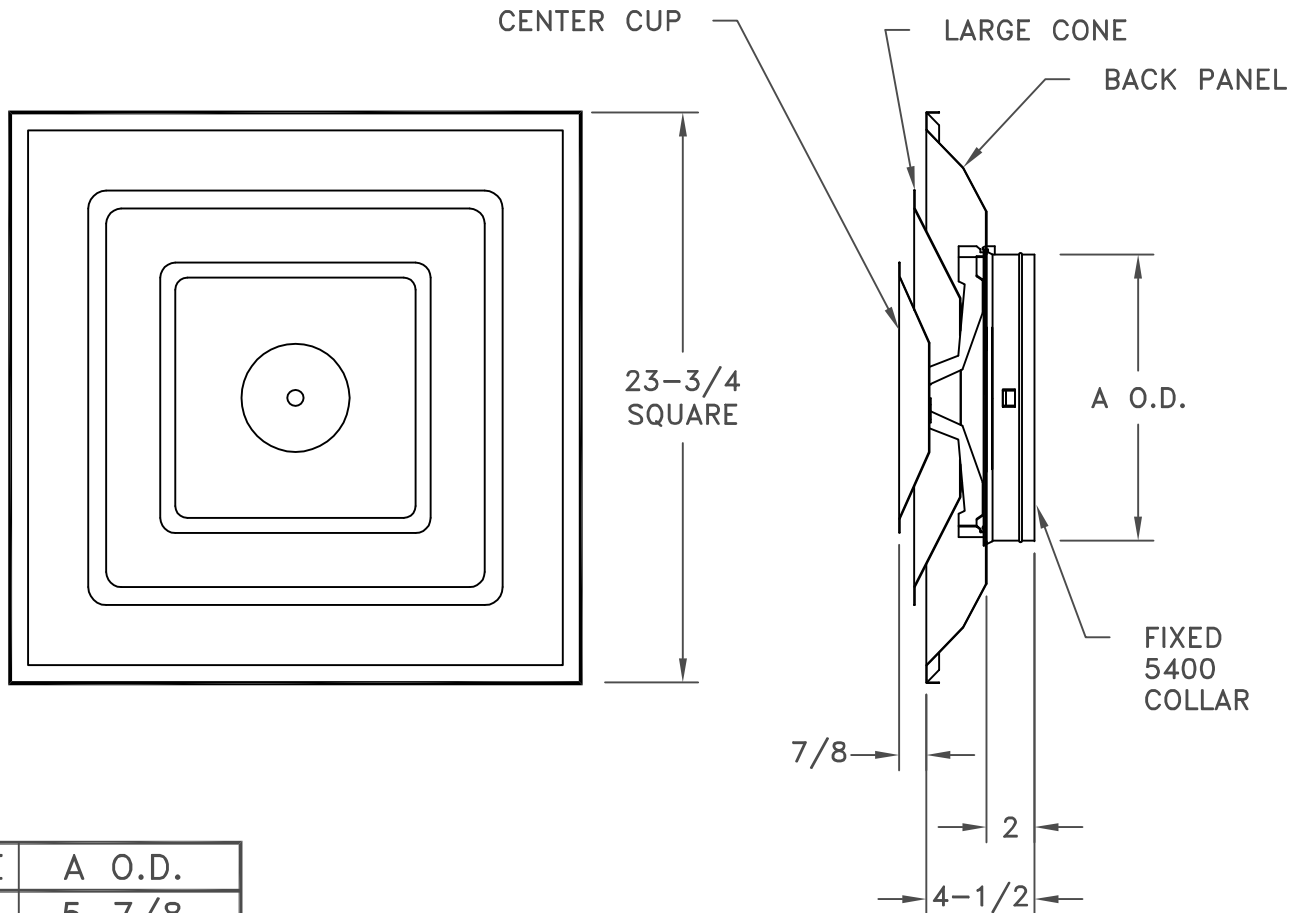

SIZE	A O.D.
6	5-7/8
8	7-7/8
10	9-7/8
12	11-7/8
14	13-7/8

JOB NAME: _____
 LOCATION: _____
 ARCHITECT: _____
 ENGINEER: _____
 CONTRACTOR: _____

SUBMITTED BY: _____

DATE: 07/17/2013 SD-9300
AFPD
 Aluminum
 Fixed Pattern
 Diffuser