

- EXTRUDED ALUMINUM CONSTRUCTION
- ADJUSTABLE BARS ON 1 INCH CENTERS
- SCREW HOLE LOCATIONS STANDARD UNLESS OTHERWISE SPECIFIED
- FOR SCREW HOLE LOCATIONS SEE SD-9140
- MINIMUM SIZE: 6 X 4
- MAXIMUM SIZE: 36 X 36
- AVAILABLE IN 1 INCH INCREMENTS
- 1-WAY, 2-WAY, 3-WAY AND 4-WAY DEFLECTIONS AVAILABLE
- FINISH: WHITE (W) ENAMEL OR SATIN ANODIZED (SA)
- Z-FRAME IS AVAILABLE SPECIAL ORDER ONLY

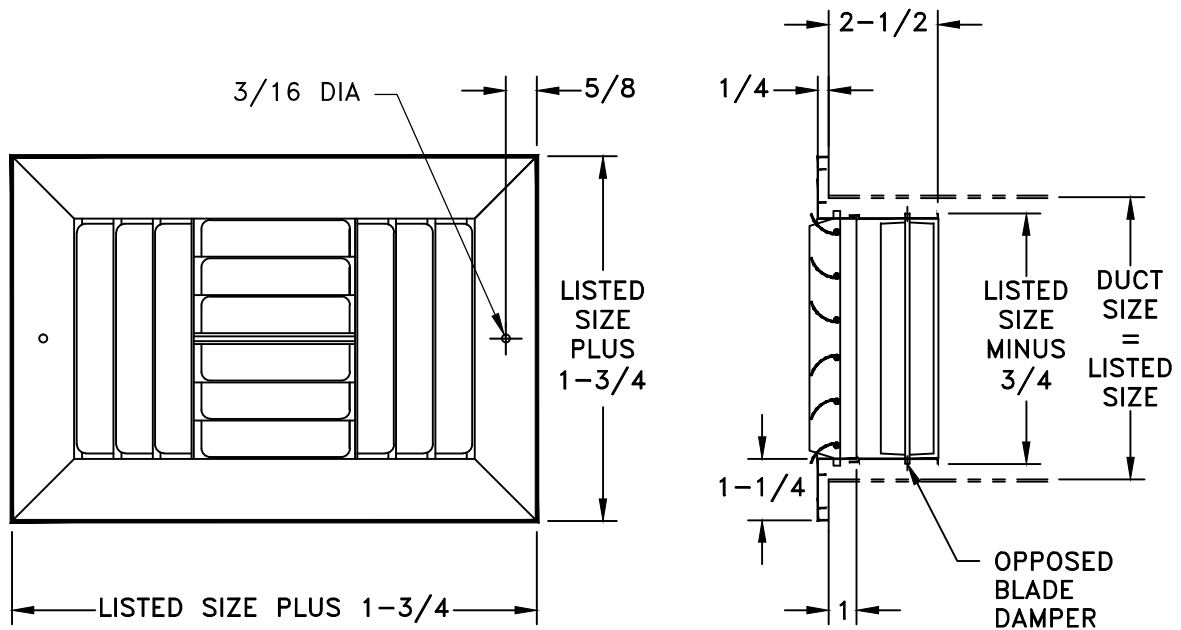

CD4 REGISTER SHOWN

JOB NAME: _____	SUBMITTED BY: _____	DATE: 03/08/2021	SD-9102
LOCATION: _____	CD SERIES Extruded Aluminum Adjustable Curved Blade Registers With Opposed Blade Dampers		
ARCHITECT: _____			
ENGINEER: _____			
CONTRACTOR: _____			