

- ALL STEEL CONSTRUCTION
- PERFORATED FACE
- OPTIONAL OPPOSED BLADE DAMPER*
- OPTIONAL T-BAR LAY-IN FRAME: 24X24 OR 24X48
- MINIMUM SIZE: 6 X 4
- MAXIMUM SIZE: 48 X 48
- FINISH: WHITE (W) ENAMEL

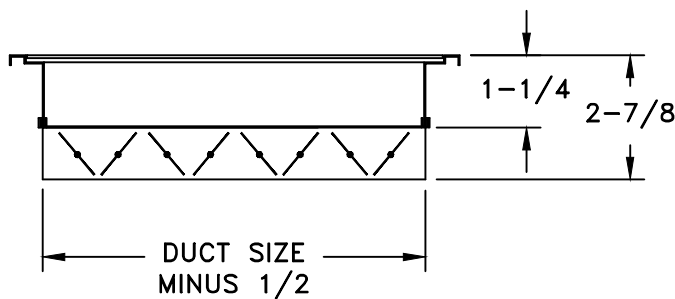

FACE DETAIL

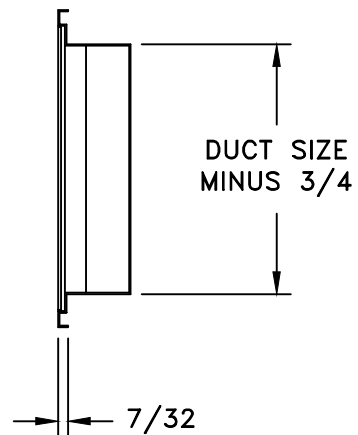
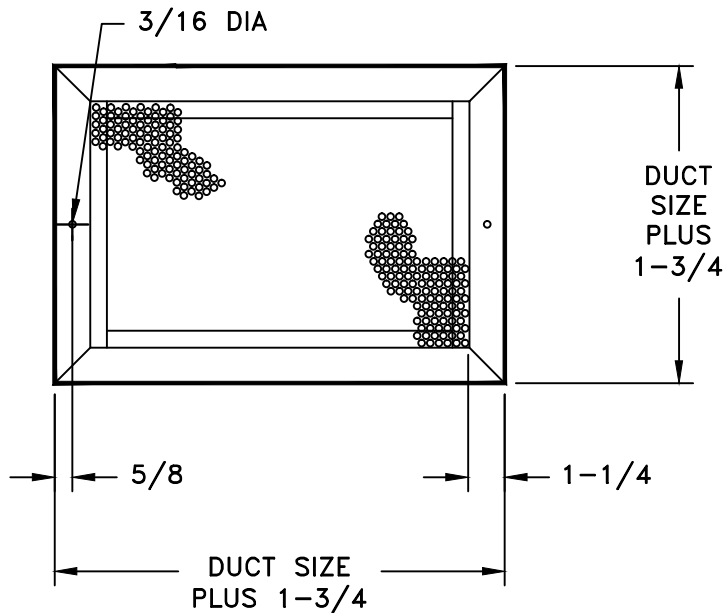
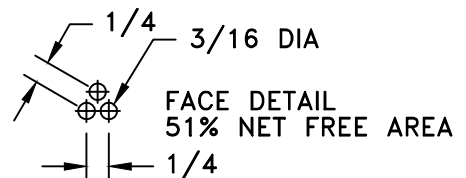

MODELS AVAILABLE

- PFG (W x H) W
- PFGOBD (W x H) W
- PFG (W x H) TP (W x H panel size) W

*FIELD TAP ACCESS HOLE IN PFG FACE TO OPERATE

JOB NAME: _____

LOCATION: _____

ARCHITECT: _____

ENGINEER: _____

CONTRACTOR: _____

SUBMITTED BY: _____

DATE: 03/08/2021 | SD-9002

PFG
Perforated Face Grille