

- ALUMINUM MULTI-PIECE FACE CONSTRUCTION WITH ADJUSTABLE ALUMINUM CURVED BLADES
- GALVANIZED STEEL MULTI-LOUVERED DAMPER
- 3/4" FIN SPACING
- FINISH: WHITE (W) ENAMEL

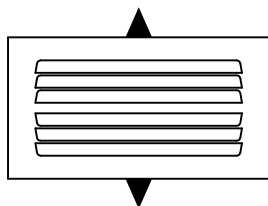

**A712MS**

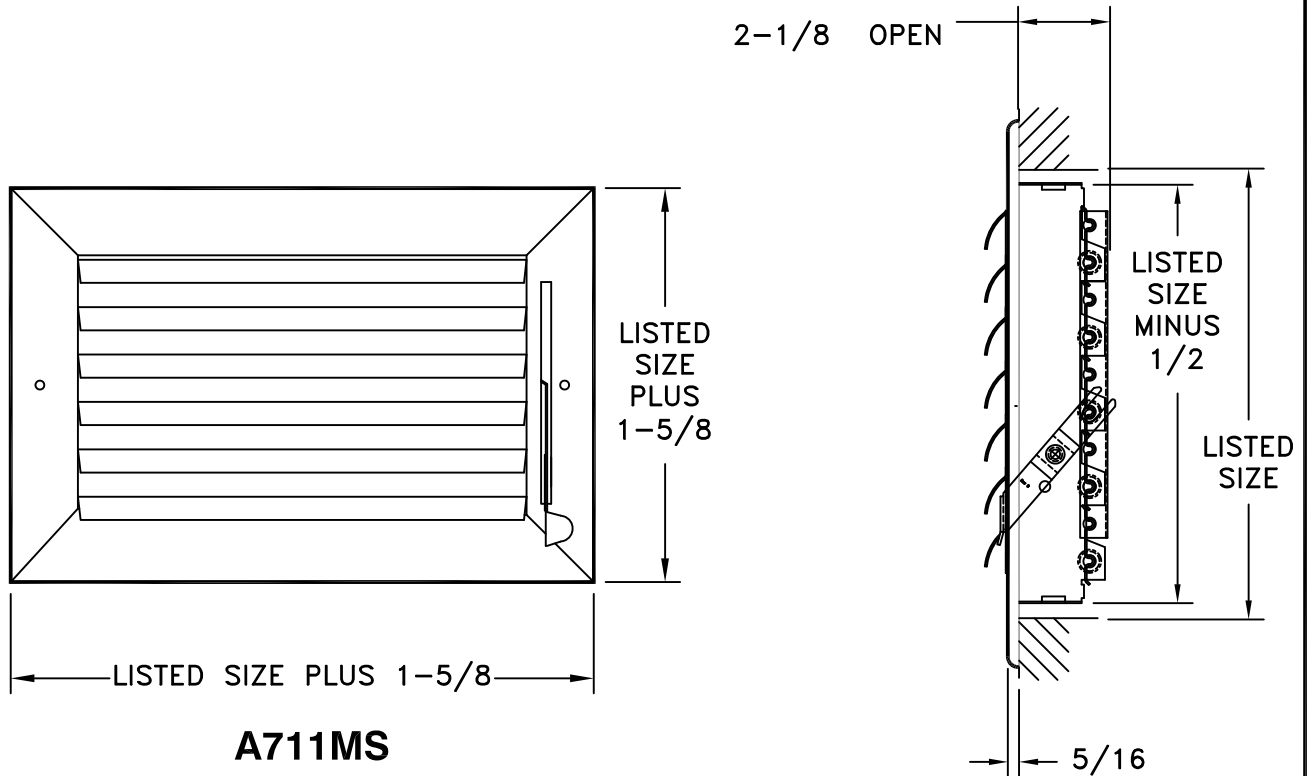
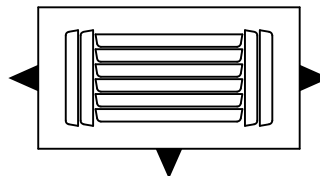

**A713MS**

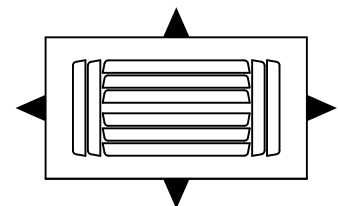

**A714MS**

DAMPER AND DIMENSIONS ARE TYPICAL FOR ALL DEFLECTIONS

JOB NAME: \_\_\_\_\_  
 LOCATION: \_\_\_\_\_  
 ARCHITECT: \_\_\_\_\_  
 ENGINEER: \_\_\_\_\_  
 CONTRACTOR: \_\_\_\_\_

SUBMITTED BY: \_\_\_\_\_

DATE: 08/22/2017 | SD-2515

**A700MS SERIES**  
 Aluminum Curved Blade  
 Register