

- ALUMINUM FACE, GALVANIZED STEEL OPPOSED BLADE DAMPER
- ADJUSTABLE CURVED BLADES
- MINIMUM SIZE = 8 X 8
- MAXIMUM SIZE = 14 X 8
- FINISH: WHITE (W) ENAMEL

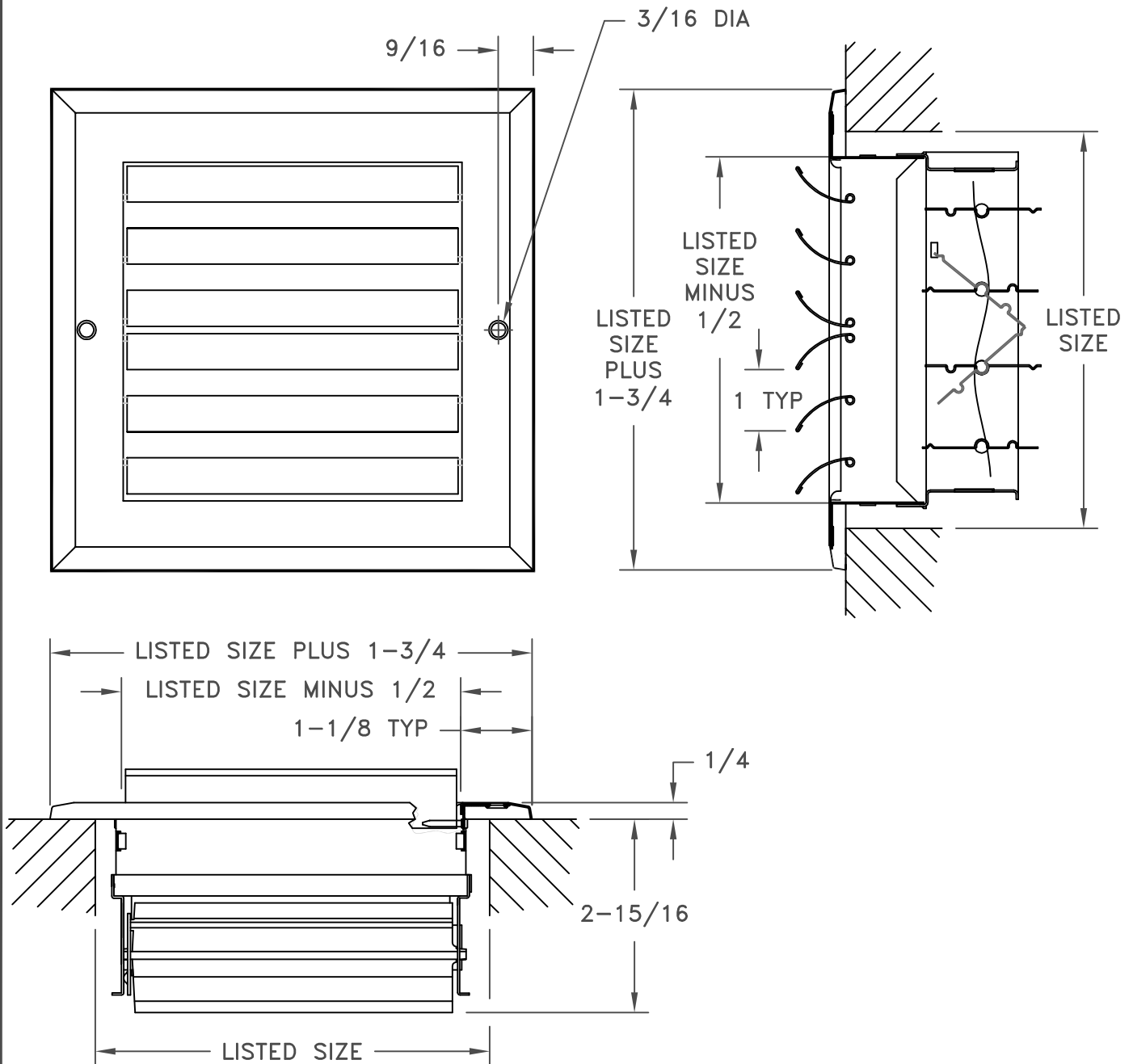

JOB NAME: _____	SUBMITTED BY: _____	DATE: 08/15/2013	SD-2507
LOCATION: _____		A612-OB	
ARCHITECT: _____		Aluminum, Curved Blade Register	
ENGINEER: _____		With Galvanized Steel	
CONTRACTOR: _____		Opposed Blade Damper 2-Way Air Pattern	