

- ALL STEEL CONSTRUCTION
- MOLDED R6 FIBERGLASS INSULATION COVERS BACKPANEL
- FITS STANDARD 2' X 2' T-BAR CEILING SYSTEMS
- ACCEPTS 5400 SERIES COLLAR, SIZES 6 - 12, ORDERED SEPARATELY
- REMOVABLE FACE PLATE
- USE NO. 3800 STEEL BUTTERFLY DAMPER (PLATE MUST BE REMOVED)
- 360° PATTERN DELIVERY
- FINISH: WHITE (W) ENAMEL

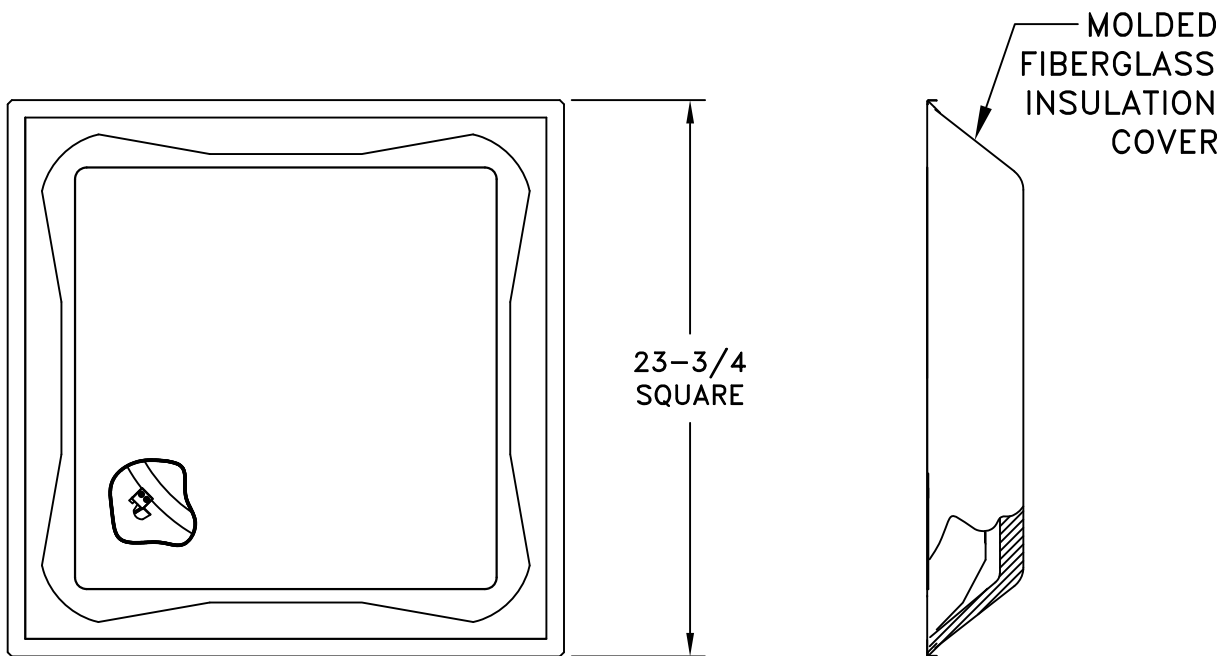

REMOVING FACE PLATE:

1. REMOVE BLACK PUSH PINS FROM HOOKS.
2. PUSH THE FACE PLATE TOWARDS THE BACK PANEL. THIS WILL DIS-ENGAGE THE HOOKS FROM THE BACKSIDE PANEL SLOTS (DETAIL A).
3. ROTATE THE FACE PLATE COUNTER-CLOCKWISE AND PULL PLATE AWAY FROM BACK PANEL AND HOOKS THRU THE SLOTS.

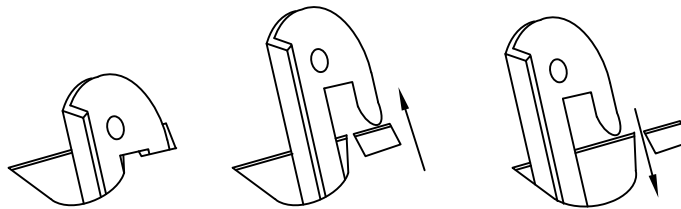

DETAIL A
(located under insulation)

JOB NAME: _____	SUBMITTED BY: _____	DATE: 06/12/2024	SD-9448
LOCATION: _____		DPD R6 Universal	
ARCHITECT: _____		Steel	
ENGINEER: _____		Detachable Plate Diffuser	
CONTRACTOR: _____		With R6 Insulation	