

- EXTRUDED ALUMINUM CONSTRUCTION
- STYLES WITH FRONT BANK HORIZONTAL:  
HV DOUBLE DEFLECTION GRILLE  
HVD DOUBLE DEFLECTION WITH DAMPER
- BARS ARE ON 3/4 INCH CENTERS AND INDIVIDUALLY ADJUSTABLE
- CHANNEL BRACE IS ADDED WHEN EITHER DIMENSION IS 48 INCHES OR OVER
- SCREW HOLE LOCATIONS STANDARD UNLESS OTHER WISE SPECIFIED
- FOR SCREW HOLE LOCATIONS SEE SD-9140
- MINIMUM SIZE: 6 X 4
- MAXIMUM SIZE: 72 X 48 OR 48 X 96 ONE PIECE CONSTRUCTION
- AVAILABLE IN 1 INCH INCREMENTS
- FINISH: WHITE (W) ENAMEL OR SATIN ANODIZED (SA)
- Z-FRAME AVAILABLE SPECIAL ORDER ONLY

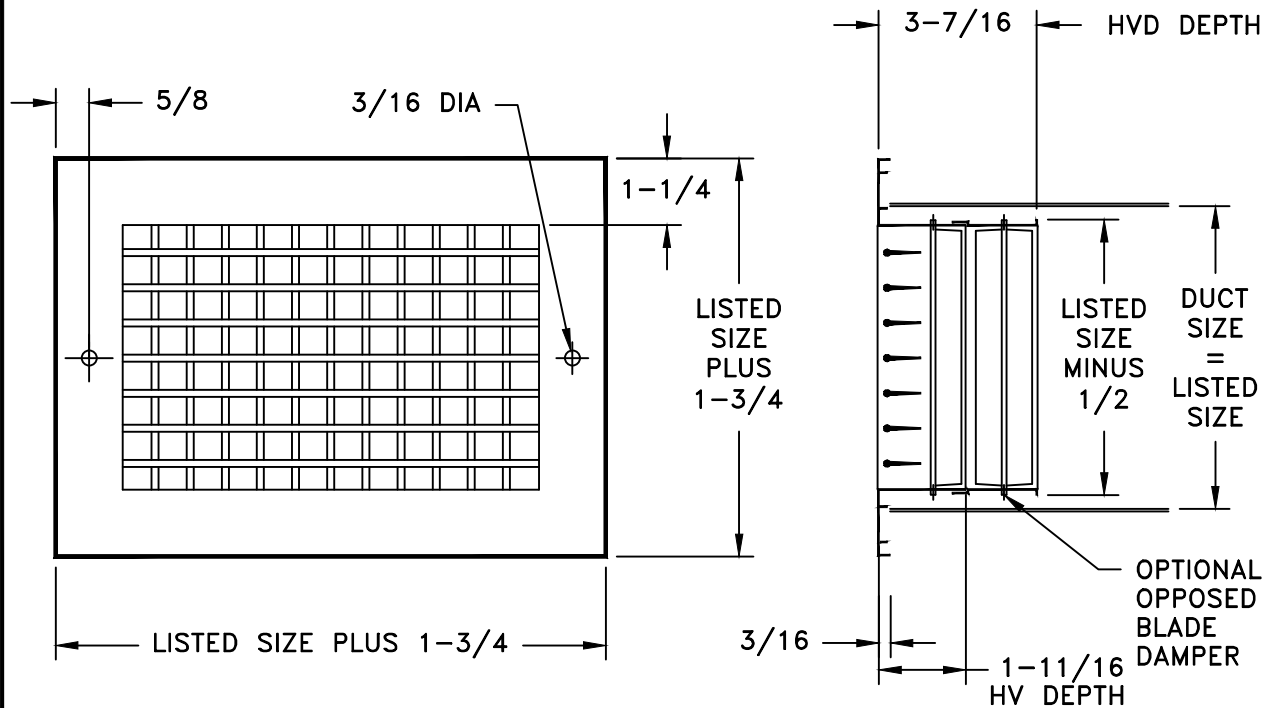

JOB NAME: _____	SUBMITTED BY: _____	DATE: 03/08/2021	SD-9110
LOCATION: _____		<b>H SERIES</b> Extruded Aluminum Grilles And Registers Adjustable Horizontal And Vertical Face Bars	
ARCHITECT: _____			
ENGINEER: _____			
CONTRACTOR: _____			