

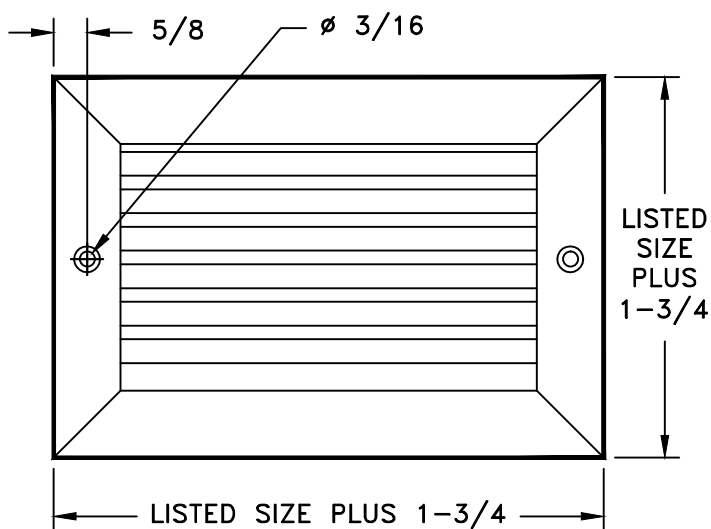

- EXTRUDED ALUMINUM CONSTRUCTION
- BARS ON 3/4 INCH CENTERS
- SCREW HOLE LOCATIONS STANDARD UNLESS OTHERWISE SPECIFIED
- WALL OR DUCT OPENING SHOULD BE DUCT SIZE +/- 1/8"
- MINIMUM SIZE: RH45 4 X 4 RHD45 4x6
- MAXIMUM SIZE: 48 X 48 ONE PIECE CONSTRUCTION
- AVAILABLE IN 1/4 INCH INCREMENTS
- FINISH: WHITE (W) ENAMEL OR SATIN ANODIZED (SA)

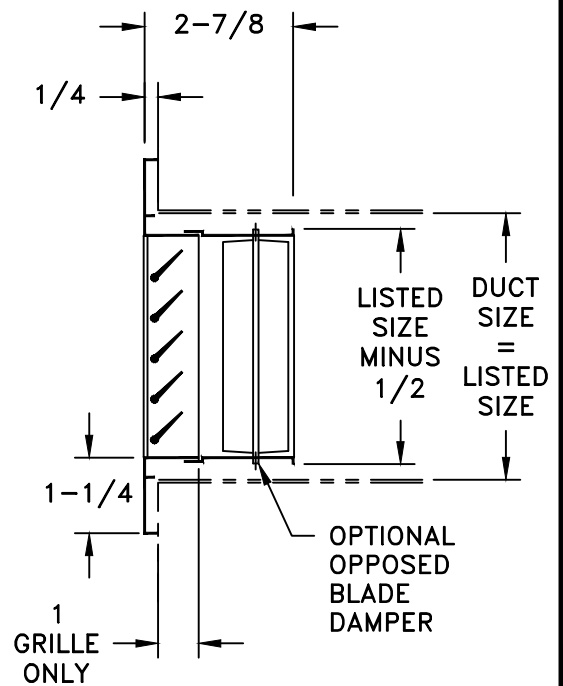

RH45LF REGISTER



RHD45LF REGISTER

NOTE: All dimensions are +/- 1/16"

JOB NAME: _____	SUBMITTED BY: _____	DATE: 03/08/2021	SD-9131
LOCATION: _____		RH45LF/RHD45LF Extruded Aluminum Fixed Horizontal Face Bars	
ARCHITECT: _____			
ENGINEER: _____			
CONTRACTOR: _____			