

- EXTRUDED ALUMINUM CONSTRUCTION
- HINGES LOCATED AT BOTTOM ON WIDTH DIMENSION
- REMOVABLE FACE
- OPTIONAL FACE MOUNTING HOLES WITH SCREWS
- BARS ON 3/4 INCH CENTERS
- FILTER FRAME MAY BE SCREW FASTENED TO DUCT
- USES NOMINAL 1 INCH FILTERS. SEE SD-9126-1 FOR 2-5" DEPTHS.
- FILTER SIZE EQUALS LISTED SIZE MINUS 1/4 INCH
- MINIMUM SIZE: 6 X 6
- MAXIMUM SIZE: 48 X 48 ONE PIECE CONSTRUCTION
- AVAILABLE IN 1/4 INCH INCREMENTS
- FINISH: PAINTED WHITE (W) OR PAINTED ALUMINUM (AL)

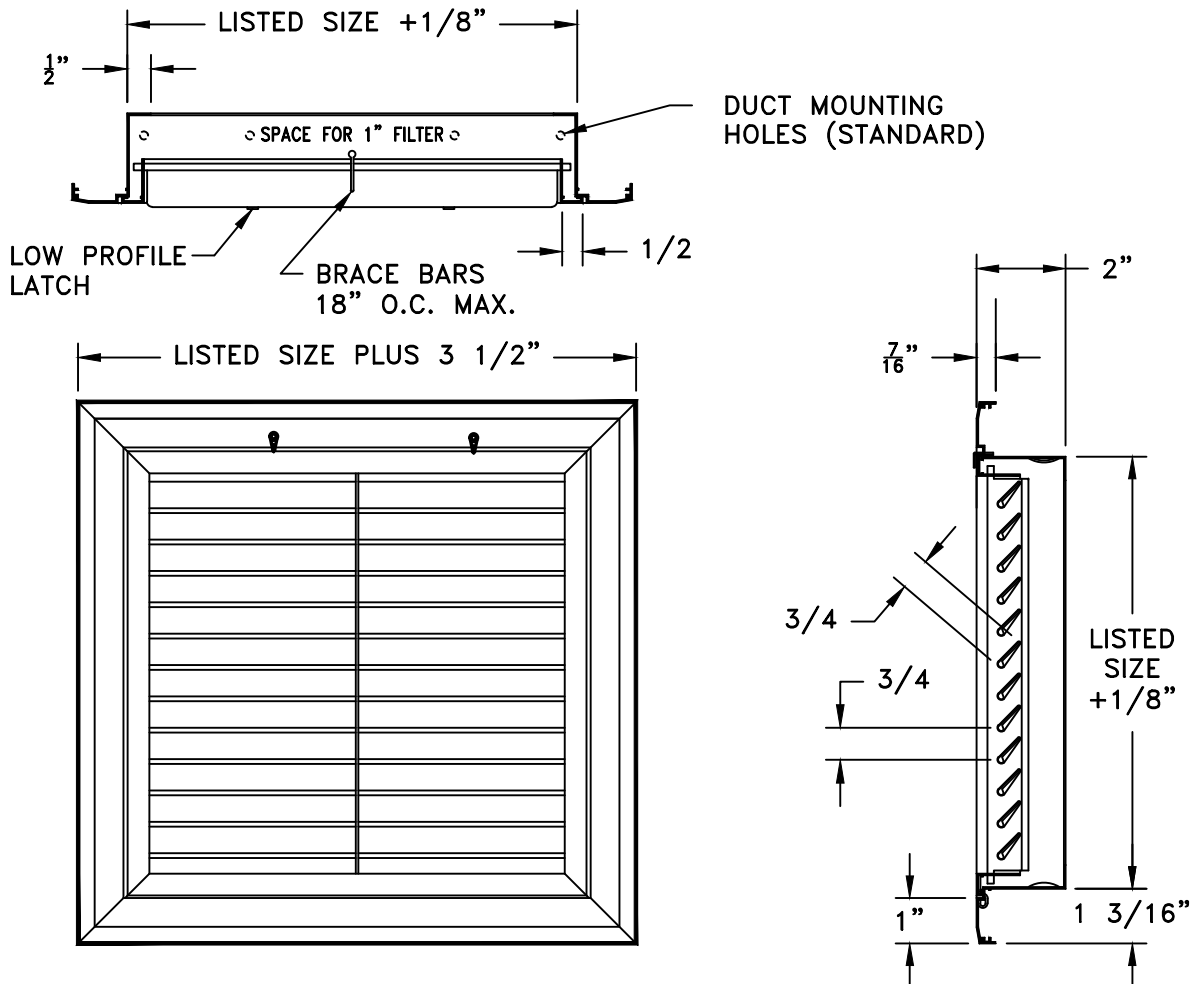

JOB NAME: _____	SUBMITTED BY: _____	DATE: 10/16/2019	SD-9126
LOCATION: _____		RHF45 Extruded Aluminum Return Air Filter Grille	
ARCHITECT: _____			
ENGINEER: _____			
CONTRACTOR: _____			