

- EXTRUDED ALUMINUM CONSTRUCTION
- BARS ON 3/4 INCH CENTERS
- SCREW HOLE LOCATIONS STANDARD UNLESS OTHERWISE SPECIFIED
- FOR SCREW HOLE LOCATIONS SEE SD-9140
- MINIMUM SIZE: 6 X 4
- MAXIMUM SIZE: 48 X 48 ONE PIECE CONSTRUCTION
- AVAILABLE IN 1 INCH INCREMENTS
- FINISH: WHITE (W) ENAMEL OR SATIN ANODIZED (SA)

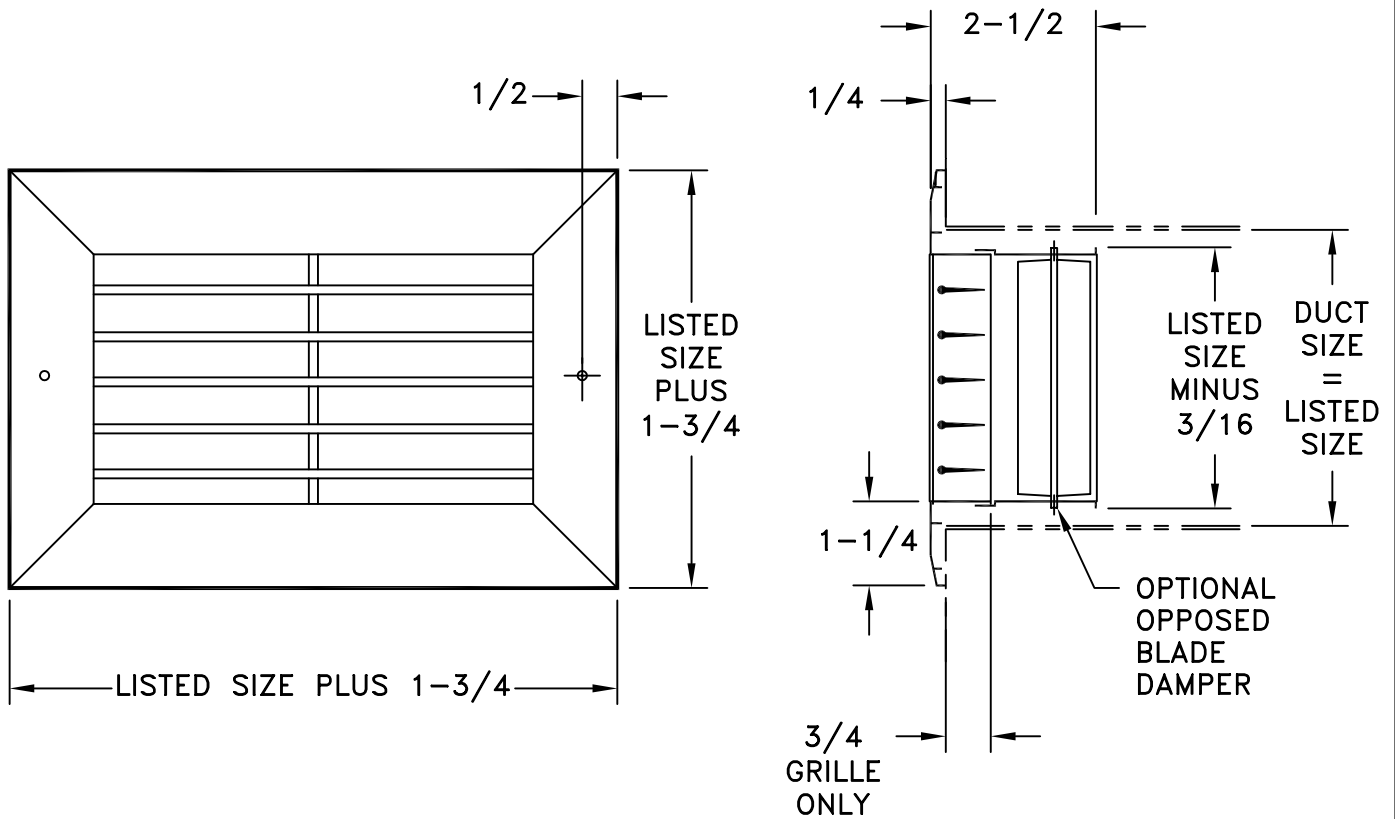

## RHD90 REGISTER

JOB NAME: _____	SUBMITTED BY: _____	DATE: 08/30/05	SD-9125
LOCATION: _____		<b>RH90</b>	
ARCHITECT: _____		Grilles And Registers	
ENGINEER: _____		Extruded Aluminum	
CONTRACTOR: _____		Fixed Horizontal Face Bars	