

Model TLC Installation Instructions

Sheet
S-3

Covering - Deluxe Rain Cap, Flashing,
Storm Collar, Spark Arrester

Read Sheet GS for important clearance and safety precautions before installing any of the parts described in this sheet. Sheet GS is packaged with supports. **IMPORTANT: 10" to 14" are non-HT.**

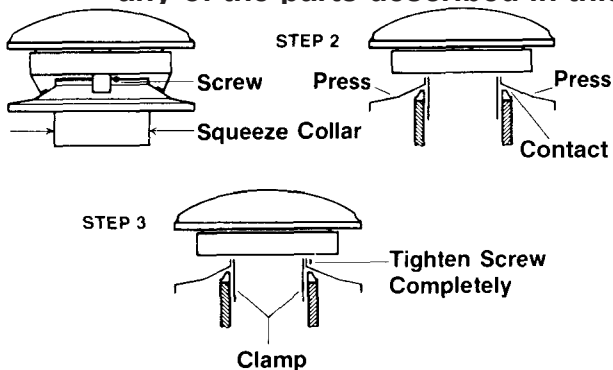

Figure 1 Round Chimney Cap Attachment

Some Model TLC deluxe rain caps have a nominal inch diameter expanding utility attachment adaptable to Model TLC Chimney and other products of like internal diameter. To attach securely:

1. Loosen screw on top of collar and squeeze bottom to allow collar to enter pipe.
2. Press down evenly on lower skirt until it contacts upper end of pipe.
3. Tighten screw on collar to expand lower end, and clamp to inside of pipe. Keep tightening screw until collar is expanded and fully tight.

STORM COLLAR

Model TLC Chimney flashings are provided with screened ventilation openings or slots at the top of the cone. In service, these openings are protected from rain by the storm collar. **DO NOT SEAL THESE OPENINGS. Make sure the openings are not obstructed when installing the storm collar.**

In unoccupied attics, the flashing termination will provide a small amount of ventilation. If this ventilation is not desired, the underside of the roof or ceiling may be trimmed and closed with a pitched ceiling plate or a fitted metal plate. All Model TLC Chimney flashings have adequate interior space for a roof support. See Sheet S-4 for roof support details.

If you are installing a chimney with flashing and storm collar, follow these steps:

1. Finish the chimney to its desired height. Maintain a 2-inch clearance to combustibles where the chimney passes through the roof.
2. Place the flashing suitable for the roof pitch over the chimney pipe, and nail securely to the roof through side and top flanges. (DO NOT nail through lower flange.) Use nails with a neoprene washer, or cover the nail heads with a waterproof mastic.

WARNING

Failure to follow these Installation Instructions could cause FIRE, CARBON MONOXIDE POISONING, OR DEATH. If you are unsure of installation requirements, call the phone number listed on the back of these instructions.

Termination Height of
Chimney Should Conform
to Building Codes

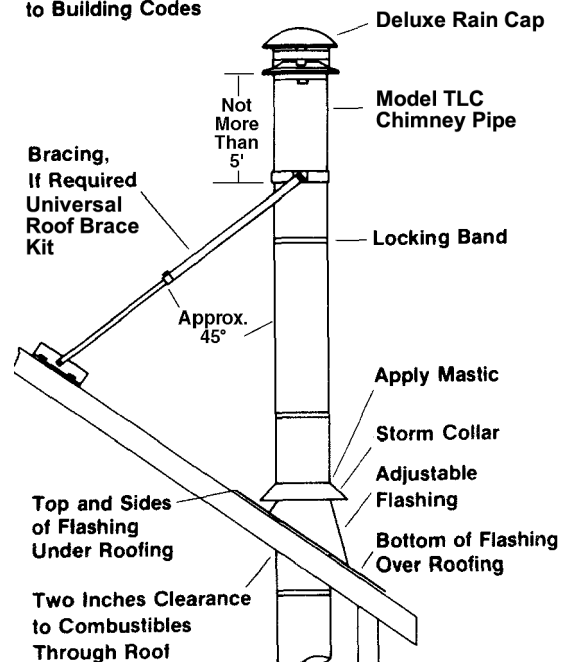

Figure 2 Chimney Flashing & Bracing

3. Finish roofing around chimney, covering the side and upper areas of the flange with roofing material. However, be sure the lower unnailed portion of the flange covers the roofing material. See Figure 2.
4. Place the storm collar down over the chimney until it touches the flashing. Tighten the adjusting screws or tabs until the storm collar fits snugly against the pipe. Work in a waterproof mastic between the pipe and the storm collar. (Roof shield included with tall cone flashing. See Figure 3.)

BRACING REQUIREMENTS WHEN USING ROUND CHIMNEY ASSEMBLY

These requirements apply to roof-supported chimneys, using the roof support, and to chimneys supported below the roof.

1. Up to four feet of chimney above the roof.
 - a. NO bracing required above roof;

- b. BUT a roof-supported chimney must be stabilized below the roof by a pitched ceiling plate.
- c. Normally a chimney will be stabilized by its support or firestop below.

REGARDLESS of height, if the chimney cannot be stabilized below the roof, use the universal roof brace kit, or construct a suitable bracing system.

2. Over 5 feet above the roof.
 - a. As a general rule, clamp the support band to the chimney at a point about $\frac{2}{3}$ of height above the roof. The angle of the support braces to the chimney should be approximately 45 degrees. (See Figure 2.)
 - b. Depending on roof slope and chimney height, it may be necessary to locate the support band at a height lower than the desired $\frac{2}{3}$. This is acceptable as long as the installation complies with the following.
 - 1) Never locate the support band lower than $\frac{1}{2}$ of the height of the chimney above the roof.
 - 2) The height of the chimney above the support band does not exceed 5 feet. (See Figure 2.)
 - 3) Do not extend braces (which adjust from 4 feet to 7 feet) farther than 7 feet. Some installations may require the use of more than one set of braces.
3. Up to 10 feet above the roof, use one brace.
4. Over ten feet above the roof, use one brace 4 feet up and one every 5 feet thereafter.

The preferred location for the support band is next to a joint, immediately above or below a locking band. The purpose of the bracing is to hold the chimney against wind loads.

In areas of heavy snow or ice accumulation, the braces and chimney may require additional protection, such as a splitter, to prevent damage to the chimney system. Check with local chimney professionals to assess need/options for such product.

Steps:

1. Install flashing and storm collar in usual manner. See Figure 2.
2. Build chimney to desired height, and locate external guy band at $\frac{1}{2}H$ above the roof.
3. Bolt brace tubes to band, and attach angle brackets to roof with lag screws into structure, bending brace and tabs as necessary. Braces should be at a 45-degree angle to the chimney or at any convenient angle when at minimum length (4 to 6 feet total). Included angle between the braces in plan should be 90 degrees.
4. Tighten end clamps on larger bracing tube.
5. The underside of the opening through an exposed ceiling may be trimmed with a flat metal plate (or pair of half-plates) cut to a round or elliptical opening to fit the chimney pipe, or use a pitched ceiling plate.

SPARK ARRESTER

The Model TLC spark arrester is made of flexible expanded metal mesh of 18-8 stainless steel, with diamond-shaped openings roughly $\frac{1}{2} \times 1$ inch. Each size is cut to fit the same size deluxe chimney cap.

1. PLACE the mesh between dome and skirt of top. It should be midway between the inner wind band and the outer edges. See Figure 4. Do not place the screen directly against the wind band.
2. LAP ends of mesh and twist cut ends into any available opening.

If the chimney is used for venting a gas appliance, use a spark arrester to keep birds out.

If the spark arrester becomes clogged with creosote, it should be cleaned or replaced.

IMPORTANT

Burning wood and coal produces creosote, soot, and fly ash, which tend to collect in chimney flue and on termination parts, causing reduced flow of gases through the chimney. Check rain cap weekly for excessive accumulation of these normal combustion products, and clean as necessary.

Use a spark arrester if you have a shingle roof or live in a forested area.

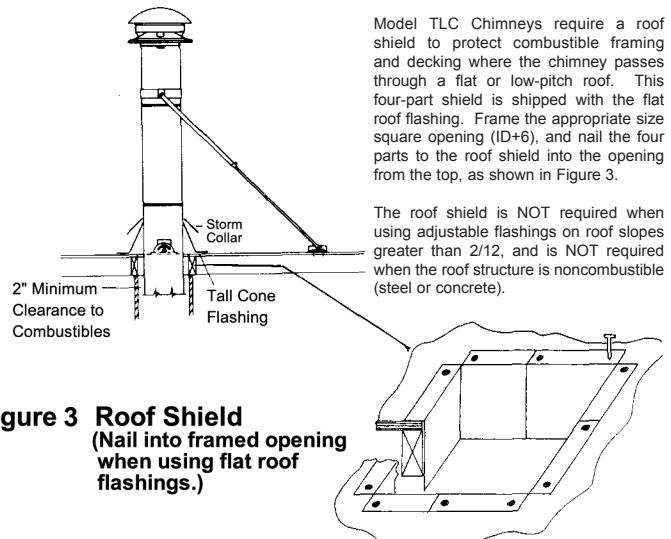

Figure 3 Roof Shield
(Nail into framed opening when using flat roof flashings.)

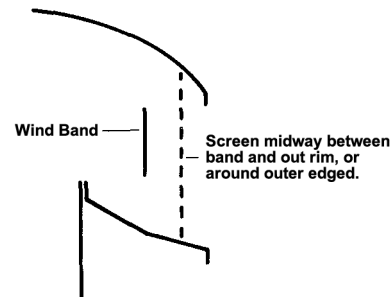

Figure 4 Proper Location of Spark Arrester Screen in Cap



hartandcooley.com
(800) 433-6341