

# Model TLC

# Installation Instructions

Sheet  
GS

## General Instructions & Owner's Maintenance Guide

Sizes 10", 12" and 14"

---

### PLEASE READ AND UNDERSTAND THE REQUIREMENTS BEFORE PROCEEDING

Use only Hart & Cooley, Inc. listed components and accessories. Do not use pipe by itself or attempt to fabricate your own support or accessories.

#### CAUTION: IF YOU ARE BURNING COAL

Some types of coal in certain designs of stoves may, in rare instances, cause corrosion of the inner parts of the Model TLC chimney system. Inspect and clean your chimney frequently to keep it free of coal, ash and soot deposits. Also, see **SIZES AND APPLICATIONS** section. If damage to the flue is observed, contact Hart & Cooley, Inc. Customer Service (800.433.6341) with a description of your chimney problem. The Model TLC chimney system is not recommended if you are burning ocean driftwood. The salt in this wood may cause product failure.

#### Minimum Clearance

Where installed within buildings, the Model TLC chimney system may be fully enclosed at 2 inches minimum AIRSPACE clearance to combustibles, including framing lumber, drywall, plaster, plywood and other building materials classed as combustible. For support framing, see table on back page.

#### Airspace Only

The minimum clearance to Model TLC chimney system pipe means AIRSPACE ONLY. The 2-inch clearance to

#### WARNING

Failure to follow these Installation Instructions could cause FIRE, CARBON MONOXIDE POISONING, OR DEATH. If you are unsure of Installation requirements, call the phone number listed on the back of these instructions.

pipe and the spaces around supports must not be filled with any type of insulation. In attics with blown-in or batt insulation, the chimney must either be fully enclosed, or an attic insulation shield must be used to create and maintain the proper minimum airspace.

#### Sizes and Applications

The instructions apply to sizes 10", 12" and 14". All three sizes comply fully with the requirements of UL Standard 103 (non-HT). Chimneys installed in accordance with these instructions will comply with national safety standards, such as NFPA 31, 54 and 211. These Model TLC chimney systems are designed for gravity venting only (natural draft). They are usable on any appliance having a power burner (such as oil furnace), if that appliance operates with neutral or negative draft at its outlet. Appliances that may cause positive pressure in the chimney should not use Model TLC. Model TLC chimney systems are ideal for venting gas (natural and LP), #2 oil, and open front wood-burning appliances (without air control).

#### SPECIAL WARNING ON CELLULOSE INSULATION

Cellulose insulation in direct contact with a hot chimney can ignite and smolder, and can set fire to ordinary wood framing materials. The AIRSPACE ONLY precaution applies to all blown-in or loose fill insulations, but is especially applicable to cellulose insulation, which may be made from old newspapers or other cellulose materials. The attic insulation shield or a suitable enclosure with appropriate firestops must be used to keep all insulation the proper distance away from the chimney.

---

**WARNING: A MAJOR CAUSE OF CHIMNEY-RELATED FIRES IS FAILURE TO MAINTAIN REQUIRED CLEARANCES (AIRSPACES) TO COMBUSTIBLE MATERIALS. IT IS OF UTMOST IMPORTANCE THAT THIS CHIMNEY BE INSTALLED ONLY IN ACCORDANCE WITH THESE INSTRUCTIONS.**

---

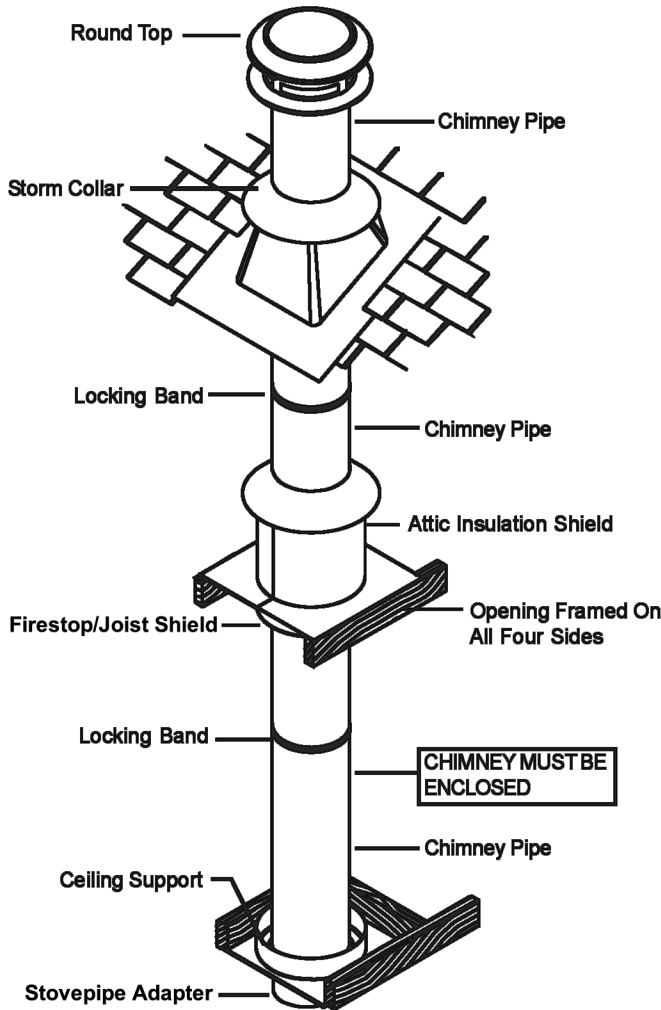

Figure 1 Vertical Chimney through One-Story and Attic

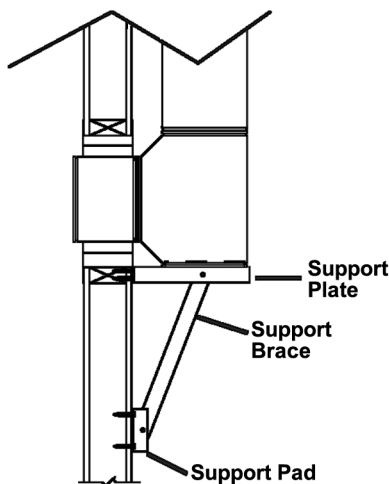

Figure 2 Wall Support for 10" and 14" Chimneys

Detail Instruction Sheets

Details for the installation of all chimney parts must be observed by referring to other instructions as follows.

Ceiling Supports\*, Connectors .....S-1  
 Attic Insulation Shields\* .....S-2  
 Round Top\*, Flashing, Spark Arrester .....S-3  
 Roof Support\*, Anchor Plate\* .....S-4  
 Insulated Tee\*, Wall Support\* .....S-5  
 Insulated Elbow\*, Interior Resupport\* .....S-5  
 Firestop / Joist Shield\* .....S-7

\*If you are installing any of these parts in packages marked\*, you should receive the proper instructions in the package. You may also request a complete set of instructions from your dealer. This sheet of general instructions is furnished with all UL-listed chimney supports. It covers important safety precautions in the installation, operation and maintenance of your appliance and chimney. Anyone installing a chimney should review this sheet, as well as those furnished with the other parts of the chimney system. Hart & Cooley, Inc. Model TLC chimney parts are LISTED and produced under the Factory Inspection and Follow-Up program of Underwriters' Laboratories, Inc. carry the LISTING MARK illustrated here.

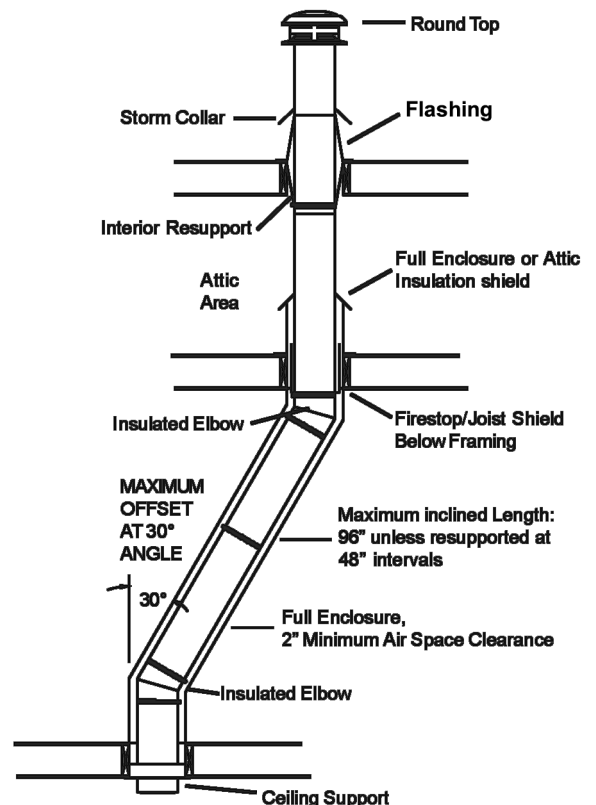

Figure 3 Thirty-Degree Offset with Enclosure at 2" Clearance (maximum of two separate offsets per system)

### WHEN INSTALLING YOUR CHIMNEY AND WOOD-BURNING STOVE OR FIREPLACE SYSTEM, REMEMBER . . . SAFETY FIRST

You may well have a basic knowledge of carpentry and the use of hand tools. However, it is important that you also review the rules of safety on the following pages. If you have any doubt about your ability to complete your installation in a workmanlike manner, you should arrange for a professional installation.

### Rules for Safety During Installation

1. Read all installation sheets. Look for them in the cartons, or ask your dealer for a complete set or download from [www.hartandcooley.com](http://www.hartandcooley.com). Keep the instructions handy and save them for future reference.
2. Check your local building or fire code for all requirements affecting the fuel-burning appliance and its chimney.
3. Obtain a building permit for both the appliance and the chimney. Contact local building or fire officials about restrictions and installation inspection in your area.
4. Be very careful around electrical wiring, and be sure it is secured at least 2 inches away from any part of the chimney. If wiring must be relocated, hire a professional electrician.
5. Be sure that ladders are in good condition, and always rest on a firm level surface.
6. Wear cut-resistant gloves when handling sheet metal parts with sharp edges.
7. Be sure that electrically powered tools are properly grounded.

### Chimney Height and Size

These instructions contain a "Selector Chart" so you can pick the exact combination of length increments. A chimney for one or more gas appliances must conform to size and height recommendations in the National Fuel Gas Code (NFPA 54). Heights above the roof as given in the next paragraph are minimum; greater heights may be needed for reasons given.

Before beginning installation of the chimney, be sure that the selected size is adequate for the appliance, and the selected height of the chimney round top termination is high enough to conform to building code requirements.

Chimneys are required to extend at least 3 feet above the highest point where they pass through the roof of a building, and at least two feet higher than any portion of a building within 10 feet. (National Fire Protection Association Standards Nos. 31, 54, and 211). See Figure 4.

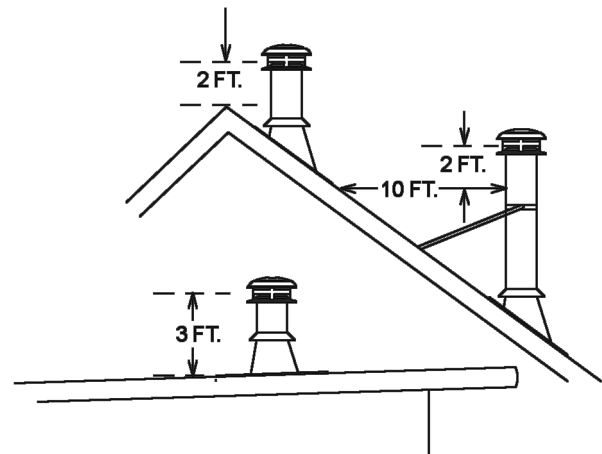

Figure 4 Rules for Chimney Height above the Roof

### Choosing Your Heating Appliance

There are three important rules for selecting a WOOD-BURNING stove, fireplace or heater.

**FIRST:** Look for a label or nameplate attached to the appliance that bears the mark or name of a well-known safety testing organization (such as Underwriters' Laboratories, Inc. or Intertek Testing Services) or laboratory.

**SECOND:** Don't buy an appliance bigger than necessary.

**THIRD:** Look or ask for complete installation, operating and maintenance instructions for the appliance. If you can't get these, buy one that gives you all these very important details.

### Appliance Safety

Be sure to follow all details of the instructions for your solid-fuel-burning appliance. You should give preference to the purchase of an appliance that either has a label or includes detailed instructions showing all required clearances to floor and walls. If necessary, these clearances may be reduced by use of a tested and "Listed" (by UL, for example) protection system, or by one of the methods described in NFPA Standard 211.

When protecting walls or ceilings from the heat of a connector, be sure to leave at least 1 inch of ventilated airspace between the protection material and combustible construction. It is ineffective and possibly dangerous to apply ordinary brick, or any similar dense material, directly to a wood-framed wall for the purpose of reducing safe clearances.

For the chimney connector, the appliance instructions take precedence over the 18-inch clearance shown in these instructions (or in building codes). The 18-inch minimum clearance dimension applies only if there is no other information for the connector.

**Each Solid-Fuel Appliance should have its own Chimney**

Open-front, freestanding or built-in fireplaces may need all the draft produced by a minimum height of chimney. Interconnecting them or their chimney with another appliance may be prohibited by their instructions and may cause smoking problems.

Never connect a gas-burning appliance into a chimney for any wood-burning stove, heater or fireplace. This is extremely dangerous, because a chimney blocked with creosote (or anything else) may cause the connected gas appliance to produce poisonous carbon monoxide.

For these and other reasons, don't ever interconnect your solid-fuel appliance with anything else, not even another solid-fuel appliance. There are simply too many things that can go wrong if you do.

**General Installation Instructions**

A correct, easily maintained chimney installation has five important parts.

1. Proper support, both vertical and lateral, with access for inspection and maintenance.
2. Adequate clearance to combustible materials for single-wall connector or smoke pipe.
3. AIRSPACE clearance of 2 inches for insulated chimney parts.
4. All vertical intermediate ceiling or floor penetrations completely framed and firestopped with specified chimney parts.
5. All connector and chimney joints completely secured against unlocking with three screws or with locking bands.

**Proper Support**

Vertical chimneys may be supported in these ways.

1. Ceiling support with all chimney stacked above. See sheet S-1.
2. Roof support, with one or more lengths suspended below and with total height limits, depending on factors such as roof pitch and height. See sheet S-4.
3. Appliance support, with the Model TLC chimney system starting at the appliance outlet. This is permissible if this method is shown in the appliance instructions, or with masonry fireplaces.
4. Wall support with insulated tee. See Sheet S-5.
5. Proper lateral support is also necessary and may be provided by wall bands, firestops, roof braces and/or all the supports listed above. Maximum spacing between components providing lateral support is 8 feet. See sheets S-2, S-3, and S-5.

Because of thermal expansion problems, only one of these support methods should be used for a vertical installation. For example, do not use both a ceiling support and a roof support for the same chimney.

**Observe Clearance to Combustible Material and Slope for Connector or Smoke Pipe**

The connector or smoke pipe is the sheet metal pipe between the appliance and the chimney. Different types of fuels and appliances have different connector clearances to combustible walls and ceilings. These clearances will be shown in the appliance instructions.

Whatever clearances and connector arrangements are shown in the appliance instructions must be followed rather than the arbitrary 18-inch dimension. This is important if tests have shown that more than 18 inches clearance is necessary, or if the location of the stove or heater necessitates more clearance. See Figure 5.

Combustible materials include such things as framing lumber, plywood, drywall (sheet rock, plaster board, lath and plaster, gypsum board), as well as furniture and curtains. Building insulation of any kind, including batts, foams, boards and especially loose fill cellulose fiber, must also be kept away from the chimney in the same manner as combustible materials.

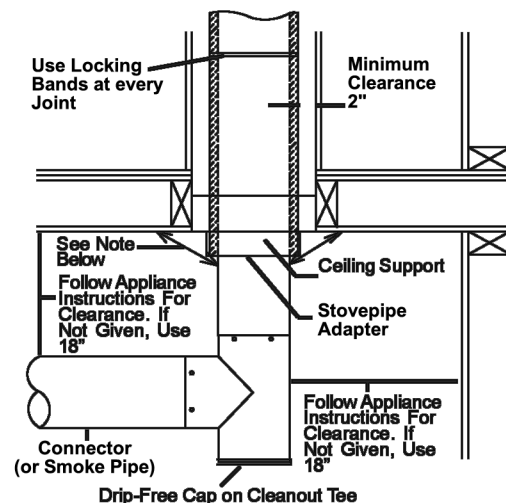

**NOTE:** The purpose of the diagonal arrows is to show that the 18-inch clearance DOES NOT APPLY to the vertical connector entering a support. This support is actually tested with a bare vertical connector and must pass the UL tests with very hot gases entering the bare single-wall pipe.

**Figure 5 Connector Clearances**

Passing a bare smoke pipe or connector of a wood-burning appliance through a combustible stud wall is not recommended, as the entire inside of the wall must be cut away to get 18-inch clearance (usually at least a 40-inch circle). Wherever possible, locate the Model TLC chimney to avoid penetrating a wall with a single-wall connector. Besides following the appliance instructions for connectors, other rules for solid-fuel appliance connectors are:

1. Never enclose vertical single-wall pipe, even at an 18-inch clearance.
2. Never run it through ceilings or floors, or windows.
3. Don't use single-wall pipe outdoors.
4. Always secure all single-wall pipe joints with at least 3 screws.
5. Obtain proper attachment parts for the appliance end and for the entry to the chimney. See the Model TLC Chimney Systems catalog for the proper size stovepipe adapter.
6. Locate and support the connector to avoid accidental contact or damage.
7. Caps or plugs for tees should be secured against falling out and designed so they can't leak creosote or rain.
8. Heavyweight, single-wall pipe lasts longer. Use 24 gauge if possible.
9. Porcelain enamel is the best high-temperature protective finish, but requires careful handling and may be difficult to assemble securely, except in a vertical position, and could produce noxious odors if overheated.
10. Galvanized steel pipe is no better than plain black or painted steel, because the galvanized zinc coating is ineffective once it has been overheated.
11. Operating the stove, heater or fireplace when the connector is red hot is very dangerous. This indicates overfiring or a chimney fire. Stop firing, close the dampers, let things cool off, and keep watching for problems on nearby walls and furnishings.
12. The slope of the horizontal portion of a connector of  $\frac{1}{4}$  inch per foot is sometimes a building code requirement. This slope will have little effect on safety or appliance operation. If the connector is vertical, it should be installed with the crimped end down. If it can be sloped between the stove and chimney, use 45-degree, one-piece, leakproof elbows (such as the corrugated type), and try to maintain sufficient slope so that any condensate liquid runs back toward the appliance. To keep liquids from coming out connector joints, the small (or crimped) end should always be down or toward the stove or fireplace.

### Clearances for Model TLC Chimney System Insulated Pipe

**All insulated Model TLC gas-carrying chimney parts are marked with important safety information confirming minimum airspace clearance to combustibles. This minimum airspace clearance to combustibles is important in order to keep combustible materials from overheating and creating a fire hazard. Never fill required airspace with insulation or even noncombustible material, since such actions could cause overheating. If you are uncertain about a particular installation, contact Hart & Cooley, Inc. at the number referenced at the end of these instructions.**

Such parts as firestops and ceiling supports are intended to be attached directly to the framing or to ceiling, or floors. These auxiliaries, which are in contact with wood or other combustibles, are designed and tested to assure that they do not overheat at points of contact.

The instruction sheets for individual parts and the table on the back page give proper framing dimensions, which in turn define the proper clearance. Wherever these instructions illustrate the use of a required spacer or firestop, the purpose of the part is to maintain and assure the proper clearance.

Remember that the most important clearance requirement is that it must be **AIRSPACE**.

**ENCLOSURE:** Interior or exterior residential chimneys should be enclosed where they extend through closets, storage areas, or habitable spaces where the surface of the chimney could be contacted by persons or combustible materials. The space between the enclosure and chimney should be at least the required 2-inch minimum airspace clearance to combustibles. (SEE SHEET S-2 FOR PROPER USE OF FIRESTOPS IN AN ENCLOSURE). **Enclosures** may be built of ordinary drywall or plywood at the required minimum of 2 INCHES AIRSPACE CLEARANCE. While properly installed firestops or supports help maintain the necessary clearances to combustibles at ceilings or joist areas, there are no special parts to maintain clearance to inside surfaces of walls or enclosures; therefore, the builder and the chimney installer should take all necessary precautions to assure that this 2-inch minimum clearance or more is maintained.

In unoccupied attics, it is very important to be sure that blown-in or other insulation does not come in contact with the chimney. A full enclosure built in the attic should extend to the roof; however, it need only be finished well enough to keep insulation and stored furnishings away from the chimney. If a full enclosure is not built, an attic insulation shield **MUST** be used. See Figure 6.

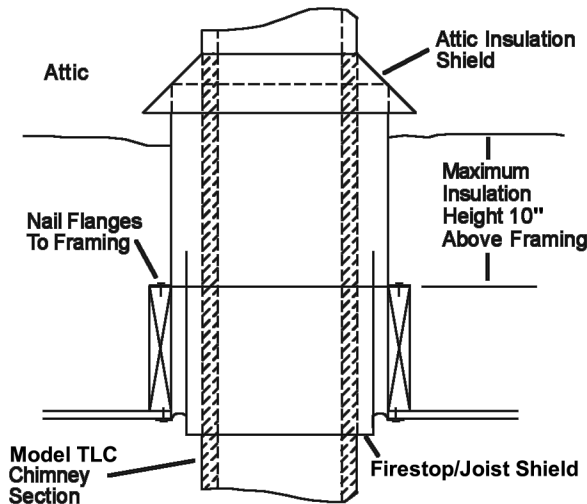

**Figure 6 Firestop/Joist Shield used with Attic Insulation Shield**

A chimney enclosure is also highly recommended for any outdoor, exterior-mounted chimney located outside of the building wall. This enclosure can be helpful in reducing internal condensation, creosote build-up and metal deterioration. Also, by protecting the chimney from cold outdoor temperatures, the enclosure may improve draft and appliance operation.

At the upper end of this outdoor enclosure, the chimney should be flashed with the flashing/storm collar termination shown in Sheet S-3.

If the enclosure is exterior, without penetration of the building enclosure, wall bands should be used to provide the necessary lateral stability.

Regardless of the benefits of the exterior enclosure, better chimney and appliance operation will be obtained if the chimney is located entirely inside the heated part of the building (except of course for the part above the roof).

Enclosures of ordinary wood framing and gypsum drywall or plywood walls may be built only in one- and two-family dwellings. For other types of buildings, multiple occupancies or high-rise construction, additional fire resistance is required for enclosures as follows.

*A factory-built chimney that extends through any zone above that on which the connected appliance is located is to be provided with an enclosure having a fire-resistance rating equal to or greater than that of the floor or roof assemblies through which it passes.*

Even with a fire-resistance rated enclosure, the use of firestops at every floor level is recommended to stabilize the chimney and to retard possible fire spread external to the chimney.

**FIRESTOPPING (See also Sheet S-2)**

A firestop is any part of the building structure that prevents the spread of a fire or circulation of air. Where a Model TLC Chimney System is enclosed and framed at 2-inch clearance, a firestop/joist shield is the proper firestop to use at every floor.

If the enclosure or space around the chimney is larger than usual, or irregular in shape, attach galvanized metal plates 28-gauge or heavier all around the edges of the firestop/joist shield as necessary. These should be wide enough so that when installed the gap is closed to vertical air circulation around the chimney, and the pipe is securely spaced and centered.

For firestopping to be fully effective, all ceiling and floor penetrations should be fully framed and closed on all four vertical sides. This framing helps delay horizontal spread of fire and controls unnecessary horizontal air leakage through intermediate floors.

**CHIMNEY JOINT SECURITY**

All Model TLC chimney joints must be reinforced with locking bands. These are furnished with pipe and elbows.

Before installing the locking band, the joint should be securely twist-locked together. Locking bands are needed to prevent accidental disengagement during chimney cleaning and to reinforce the chimney whenever it is outdoors, along walls, or above the roof.

**Warning:** The chimney pipe and its fittings must be assembled with metal-to-metal joints as furnished. Do not use tape or any sealing compound (such as tar, mastic, putty or silicone) at the outer joints. Sealers in the joints may cause the insulation to accumulate moisture and will cause corrosion or freezing failures.

**CAUTION: DO NO USE MODEL TLC CHIMNEY SYSTEM PIPE WITH DAMAGED ENDS.**

Both the inner and outer pipe must join properly to avoid leakage and accidental disengagement. Slight eccentricity of the inner pipe will not affect operation, provided that the joint goes together completely. Minor dents or irregularity of the outer pipe will not have any perceptible effect on temperature safety.

**CHIMNEY OPERATION AND MAINTENANCE**

The need for chimney maintenance depends on the kind of appliance and how it is operated. Gas and oil-burning appliances may need very little, but wood and coal-burning appliances may need a great deal of chimney maintenance. Open-front fireplaces without doors usually dilute their smoke with large amounts of air. Thus the buildup of chimney deposits is generally very low. "Airtight" or controlled draft wood stoves and heaters produce dense smoke if they are loaded for long duration or overnight fires, and can rapidly produce heavy thick creosote deposits. It is possible, by having a short duration daily hot fire, to burn off these deposits or prevent them from building up to dangerous levels. This takes skillful operation and an appreciation of how to get the correct temperature.

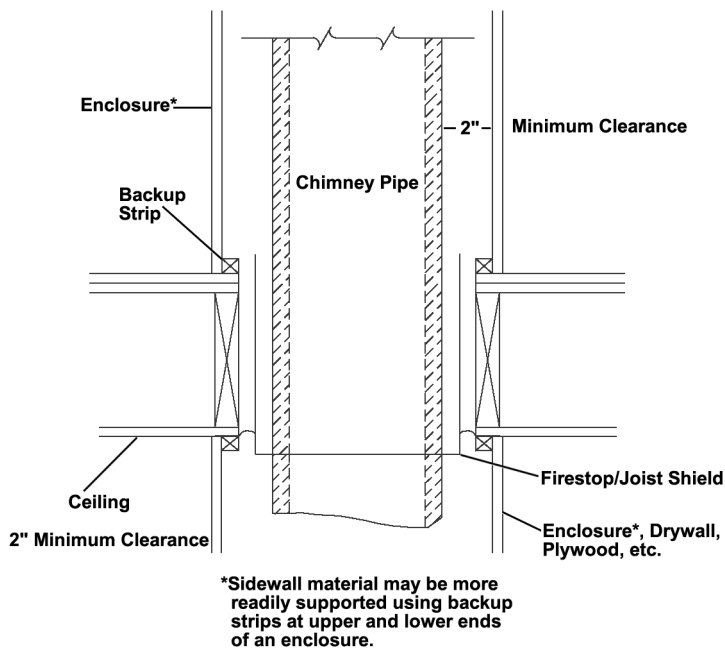

**Figure 7 Firestop/Joist Shield with Full Enclosure**

**CREOSOTE AND SOOT FORMATION AND NEED FOR REMOVAL**

When wood is burned slowly, it produces tar and other organic vapors, which combine with expelled moisture to form creosote. The creosote vapors condense in the relatively cool chimney flue of a slow-burning fire. As a result, creosote residue accumulates on the flue lining. When ignited, this creosote makes an extremely hot fire. With coal that can burn with a smoky fire, this smoke also condenses in the chimney to form soot. The chimney should be inspected at least once every two weeks during the heating season to determine if a creosote or soot buildup has occurred.

If creosote or soot has accumulated, it should be removed to reduce the risk of chimney fire.

Creosote causes many problems. Some are visible while others are not. It can make trouble if:

1. It runs down the outside of the pipe to damage the finish on the metal.
2. It drips out of joints, damaging floors or furnishings.
3. It plugs up the chimney to cause poor combustion, smoking, soiling walls and indoor air pollution.
4. It catches fire in the chimney to cause possible chimney damage and damage to your home.

If you see deposits more than 1/16 inch thick, clean all of the chimney parts mechanically. This means using brushes, scraping or equivalent. Don't start a chimney fire! With only slight deposits, try a hot fire to see if the black deposits change to light ash or fall down the chimney. You can hear the sound of falling deposits when temperature conditions are right. Afterwards, reinspect the chimney and the inside of the appliance for deposits.

Do not use chemical cleaners, they may corrode the inside of the chimney. They may or may not prevent or remove creosote. When they are used together with a hot fire, it is probably the fire that is doing the work. Depending on the rate of buildup, as you learn what is going on in the chimney, you can adjust your cleaning schedule.

If you have any doubts about your ability to clean the chimney, or if the deposits are very heavy and hard to remove, call a professional chimney sweep. Do not try to burn them off. It doesn't matter how careful you are with loading, fuel wood selection or draft control, you should observe the above precautions with any wood stove or chimney installation.

**CHIMNEY FIRES AND WHAT TO DO ABOUT THEM**

Your Model TLC chimney system is not intended or designed for use as a combustion or fire chamber. It is very easy to overfire your wood-burning appliance with kindling, scrap lumber, brush or any fast-burning fuel. This can produce flames and high temperatures all the way up the chimney, and may cause chimney damage.

If you see your appliance or the smoke pipe glowing red, you are risking chimney damage or a fire. The creosote may be burning inside the chimney. If you see flames coming out the top, you are either overfiring or there is a chimney fire. If the fire in your heater has gotten out of control, or if you suspect a chimney fire for any reason, follow these steps.

1. Immediately close all dampers and/or air entrance openings to your appliance. This includes doors on Franklin-type stoves. Block off fireplace openings.
2. Alert your family to the possible danger.
3. Inspect your appliance and chimney surroundings for possible fire. If in doubt, alert your fire department.
4. Do not continue to use your appliance until it and your chimney have been thoroughly inspected. Overheating can cause metal parts to expand, buckle and crack. If you are not certain, have a qualified heating person disassemble all parts so they can be inspected and replaced.
5. Do not use salt or water on the fire in your appliance. Salt is corrosive, and water will cause a dangerous steam explosion. You might be able to control the fire by using ashes, sand or baking soda, since baking soda is an ingredient used for dry chemical fire extinguishers.
6. After a chimney fire, when it is safe to do so, check internal locations, such as the attic and under the roof, and keep watching for two or three hours. There may be delayed smoldering and subsequent ignition, even if the fire inside the chimney has been controlled.

**Framing Dimensions for Model TLC Chimney Systems to Maintain 2" Airspace Clearance**

Chimney Size (inside diameter)	10"	12"	14"
Ceiling Support*	16¼" x 16¼"		
Ceiling Penetrations*	16" x 16"		
Floor Openings*	16" x 16"	18" x 18"	20" x 20"
Roof Openings*	16" x 16"	18" x 18"	20" x 20"
Wall Openings*	16" x 16"	18" x 18"	20" x 20"

\* All framing dimensions may be up to ½" more, but not less than the above values. Check support dimensions before using.

**Maximum Height (or Length) of Chimney for Supports**

Support Type	10", 12", 14" Feet of Chimney
Anchor Plate	85
Ceiling Support	50 (10" only)
Insulated Tee	40
Wall Support	40
Roof Support <sup>a</sup>	30
Interior Resupport	18

<sup>a</sup> 20 feet of chimney may be suspended below a roof support with all joints securely threaded, using locking bands.

**Chimney Pipe Length Selector Chart**

Ft.	In.	Total In.	Pipe Length							
			6	9	12	18	24	36	48	
Installed Height			4¾	7¾	10¾	16¾	22¾	34¾	46¾	
<b>Number of Chimney Pipe Sections</b>										
-	4¾	4¾	1							
-	7¾	7¾	1							
-	10¾	10¾	1							
1	½	12½	1	1						
1	4¾	16¾	1							
1	6½	18½	1		1					
1	10¾	22¾	1							
1	11¼	23¼	1	1	1					
2	10¾	34¾	1							
2	11¼	35¼	1		1	1				
3	3½	39½	1	1						
3	6½	42½	1		1					
3	9½	45½	1				1			
3	10¾	46¾	1							
4	2¼	50¼	1		1	1				
4	3½	51½	1				1			
4	3½	51½	1	1						
4	6½	54½	1		1					
4	9½	57½	1				1			
5	3½	63½	1				1			
5	9½	69½	1						1	
5	9½	69½	2							
6	9½	81½	1						1	
7	2¼	86¼	1				2			
7	8¼	92¼	1						2	
7	8¼	92¼	2							
7	9½	93½	2							
8	8¼	104¼	1				2			

Ft.	In.	Total In.	Pipe Length								
			6	9	12	18	24	36	48		
Installed Height			4¾	7¾	10¾	16¾	22¾	34¾	46¾		
<b>Number of Chimney Pipe Sections</b>											
9	2¼	110¼	1								2
9	8¼	116¼	1						2		
10	8¼	128¼	1							2	
9	7	115	1				3				
10	1	121	1						3		
10	7	127	1				3				
11	8¼	140¼	3								
12	7	151	1				3				
13	1	157	1						3		
13	7	163	1				3				
14	7	175	1						3		
11	7	139	4								
12	11¼	155¼	1				4				
13	5¼	161¼	1						4		
15	7	187	4								
16	11¼	203¼	1				4				
17	5¼	209¼	1						4		
18	5¼	221¼	1							4	
14	5¼	173¼	5								
16	4½	196½	1				5				
19	5¼	233¼	5								
21	4½	256½	1						5		
22	4½	268½	1							5	
17	4½	208½	6								
19	3¼	231¼	1						6		
23	4½	280½	6								
25	3¼	303¼	1						6		
26	3¼	315¼	1							6	



Hart & Cooley, Inc. 616.656.8200 p  
 5030 Corporate Exchange Blvd. SE 616.656.6399 f  
 Grand Rapids, MI 49512  
 info@hartcool.com  
 www.hartandcooley.com