

- EXTRUDED ALUMINUM CONSTRUCTION
- REMOVABLE FACE WITH KNURLED KNOB FASTENER(S) & CONCEALED HINGE
- USES NOMINAL 1 INCH DISPOSABLE FILTERS
- FILTER SIZE EQUALS LISTED SIZE MINUS 1/4 INCH
- SIZES: 20 X 20, 44 X 20
- FINISH: WHITE (W) ENAMEL OR MILL

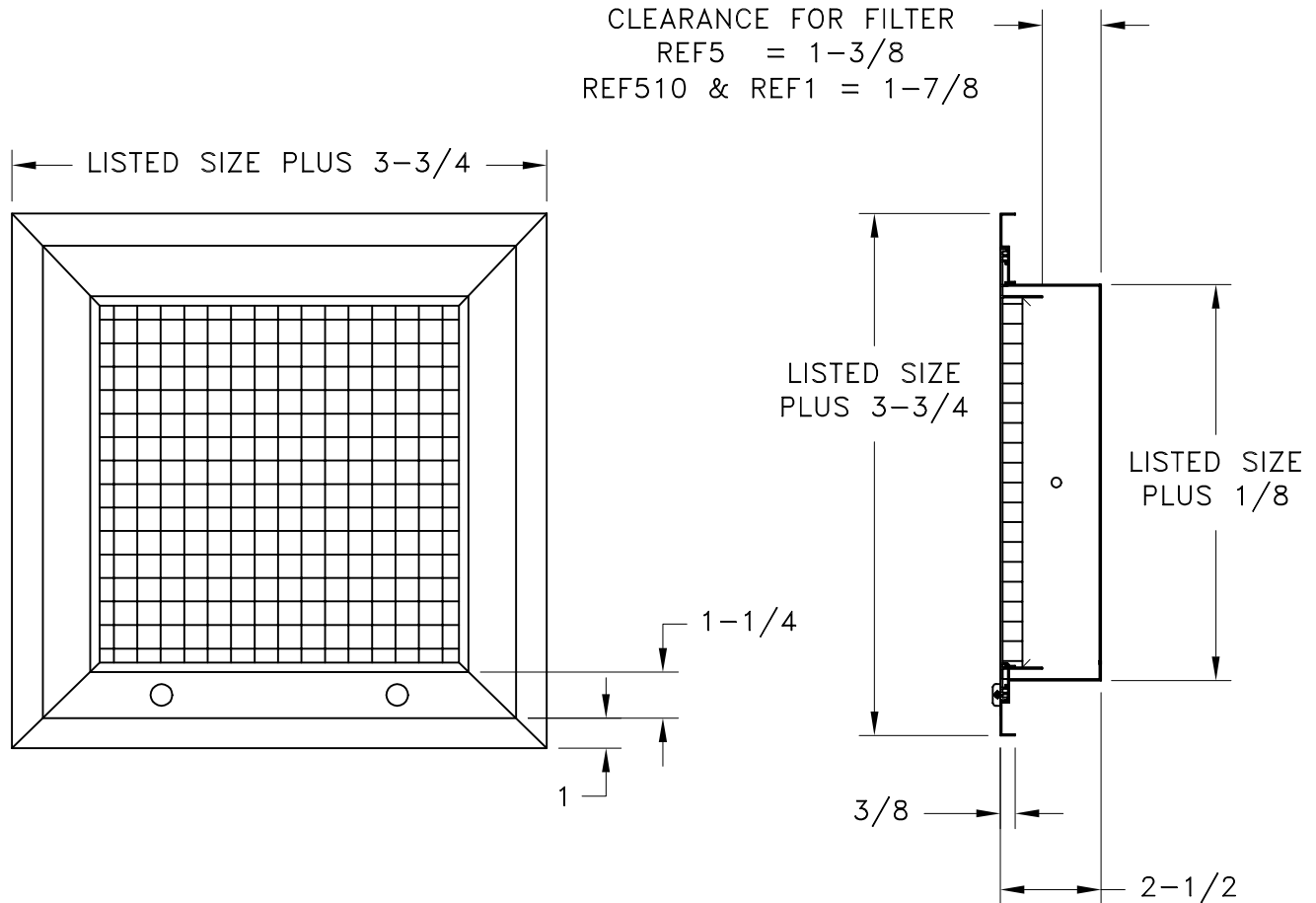

MODEL	GRID CORE DIMENSIONS
REF5-T	1/2 X 1/2 X 1/2
REF510-T	1/2 X 1/2 X 1
REF1-T	1 X 1 X 1

JOB NAME: _____	SUBMITTED BY: _____	DATE: 6/18/01	SD-9482
LOCATION: _____		<b>REF5-T, REF510-T, REF1-T</b>	
ARCHITECT: _____		Extruded Aluminum	
ENGINEER: _____		Grid Core T-Bar	
CONTRACTOR: _____		Filter Grille	