

- EXTRUDED ALUMINUM CONSTRUCTION
- HINGES LOCATED AT BOTTOM ON WIDTH DIMENSION
- CURVED BLADES FIXED ON 1 INCH CENTERS
- FILTER FRAME MAY BE SCREW FASTENED TO DUCT
- USES NOMINAL 1 INCH DISPOSABLE FILTERS
- FILTER SIZE EQUALS LISTED SIZE MINUS 1/4 INCH
- FINISH: WHITE (W) ENAMEL OR SATIN ANODIZED (SA)

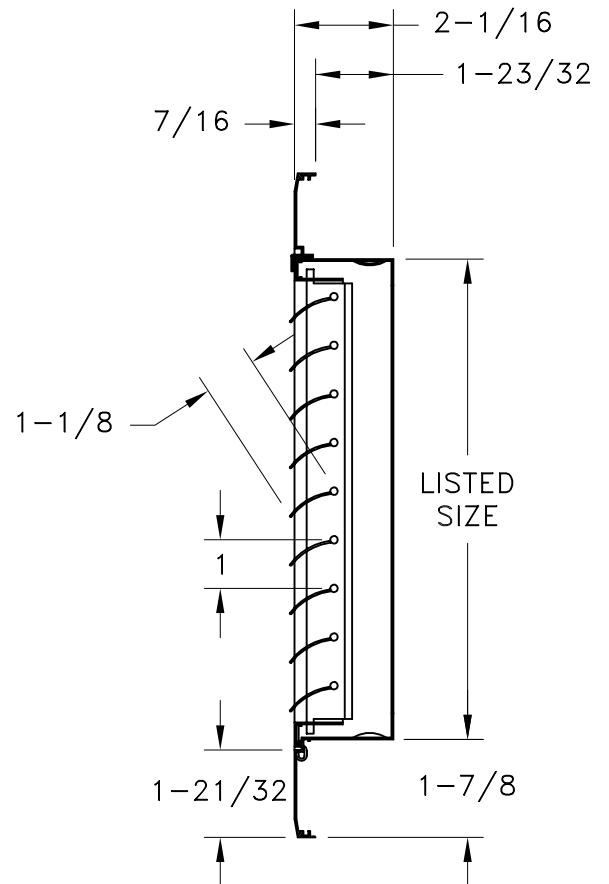
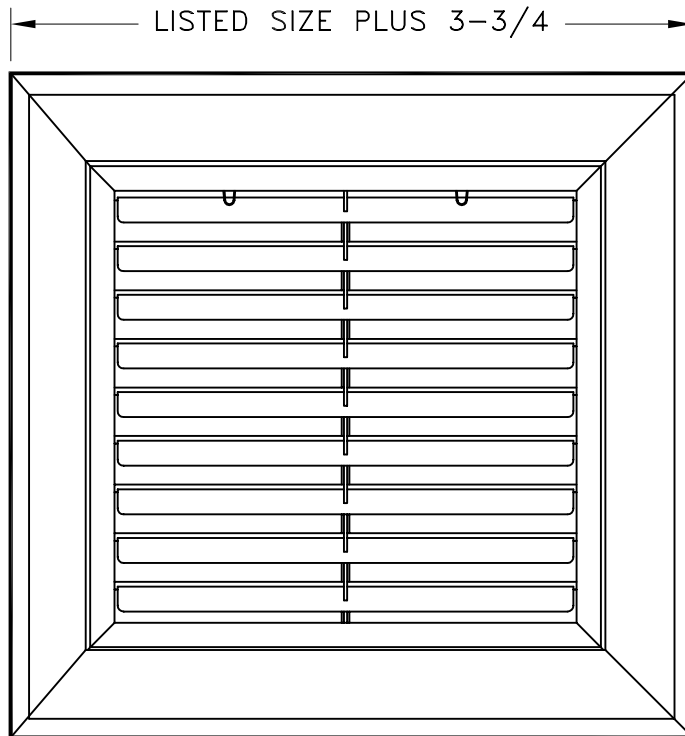
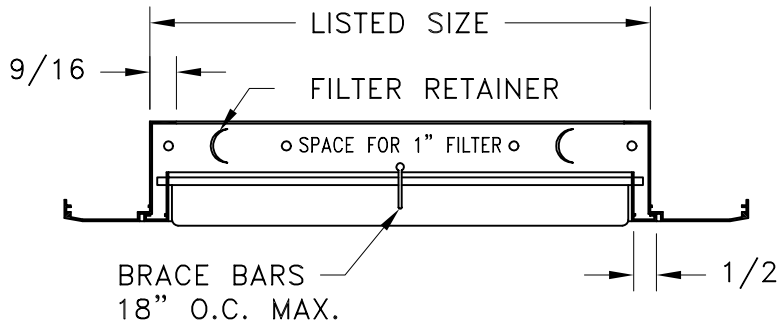

LISTED SIZE	T-BAR	OVERALL
20 X 20	24 X 24	23-3/4 X 23-3/4

JOB NAME: _____	SUBMITTED BY: _____	DATE: 11/26/02	SD-9476
LOCATION: _____		RCBF-T Extruded Aluminum RCB Grille Hinged To Filter Frame	
ARCHITECT: _____			
ENGINEER: _____			
CONTRACTOR: _____			